



GAI-TRONICS®
A DIVISION OF HUBBELL LTD

VoIP Clean Phone® Telephones

TABLE OF CONTENTS

Confidentiality Notice3

Product Overview3

Models 4

System Requirements and Limitations 4

Features and Functions 5

Operation5

Placing an Autodial Call from a VoIP Clean Phone® 5

Placing a General Telephone Call 5

Receiving a Call..... 5

Multicast Broadcast..... 6

Monitoring and Reporting 6

Installation7

General Information..... 7

Safety Guidelines..... 7

Station Placement..... 7

Model 112-02-0418-00W (Flush mounting) 8

Model 112-02-0418-01W (Surface mounting)..... 12

Setup14

Field Wire Installation..... 14

 Power 14

 Network 15

 I/O 16

 Recommended Cabling..... 17

VoIP Telephone Input Contacts 17

VoIP Telephone Output Contacts 17

Status Indication 17

 Power 17

 Heartbeat..... 17

 EACT..... 17

Programming18

VoIP PCBA Setup..... 18

 VoIP PCBA Initial Network Configuration 18

Maintenance20

General Information..... 20

Service 20

Troubleshooting 21

Specifications22



GAI-TRONICS® CORPORATION
A HUBBELL COMPANY

VoIP Clean Phone® Telephones

Confidentiality Notice

This manual is provided solely as an installation, operation, and maintenance guide and contains sensitive business and technical information that is confidential and proprietary to GAI-Tronics. GAI-Tronics retains all intellectual property and other rights in or to the information contained herein, and such information may only be used in connection with the operation of your GAI-Tronics product or system. This manual may not be disclosed in any form, in whole or in part, directly or indirectly, to any third party.

Product Overview

The GAI-Tronics Model 112-02-0418-00W Flush-Mount and Model 112-02-0418-01W Wall-Mount VoIP Clean Phone® Telephones are designed for the exacting requirements of clean rooms. They are constructed of stainless steel and have a completely smooth polyester front panel that will not trap particulate matter. Calls are made by pressing one of the three auto-dial buttons or by using the fully functional keypad. The oversized, clearly labeled buttons allow for easy operation with gloved hands.

The VoIP Clean Phone® Telephones are designed for connection to a 10/100 BaseT Ethernet network. These telephones will operate from Power-over-Ethernet or an external power source. The VoIP telephones provide direct point-to-point communications between personnel throughout the facility over the existing LAN.

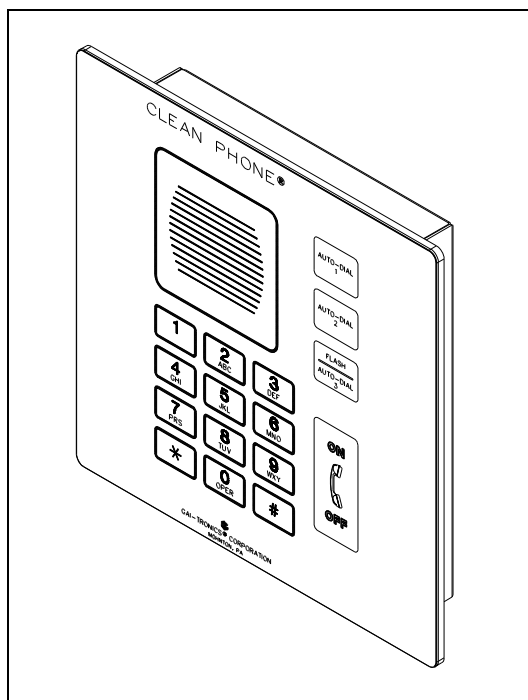

Figure 1. Model 112-02-0418-00W

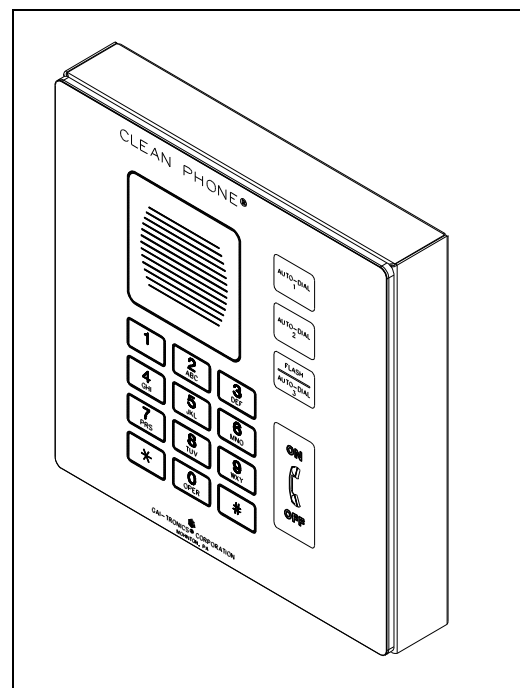

Figure 2. Model 112-02-0418-01W

Models

The following VoIP Clean Phone® Telephones are detailed in this manual:

Table 1. Model Chart

Model	Description
112-02-0418-01W	Surface-Mount VoIP Telephone including a stainless steel front panel with polyester overlay, three autodial buttons, hookswitch push button, off-hook indicator, keypad, and stainless steel surface-mount enclosure.
112-02-0418-00W	Flush-Mount VoIP Telephone including stainless steel front panel with polyester overlay; three autodial buttons, hookswitch push button, off-hook indicator, keypad, and stainless steel mounting bracket.

System Requirements and Limitations

The VoIP Telephones require Power-over-Ethernet or a local 24–48 V dc power source for operation. Two VoIP telephones can be connected in a peer-to-peer configuration without the need for a LAN. However, a 10/100 BaseT Ethernet with SIP Server is required for systems containing three or more VoIP Telephones. Conferences are limited by the customer's LAN media capabilities and the services available at each end point.

In addition to direct point-to-point dialing (peer-to-peer), directly or via a SIP server, each telephone is capable of receiving a Multicast broadcast. Multicast allows a single audio stream to be sent to multiple end points simultaneously, to achieve multi-point paging or Public Address functionality over IP. Multicast requires the use of a SIP server that specifically supports Multicast functionality and each telephone must be configured (enabled) to receive Multicast packets.

Features and Functions

The Clean Phone® Telephone's voice-over-internet protocol (VoIP) include the following features:

- SIP compatible (RFC3261)
- Automatic call divert (memory list)
- Real-time alarm reporting via email, syslog, or TMA software
- Configurable via web page, serial link or download
- Four auxiliary inputs; two volt-free contact outputs
- Multicast capability, up to eight addresses

Operation

Placing an Autodial Call from a VoIP Clean Phone®

To place an autodial call:

1. Press the desired autodial push button to place an immediate call to a preprogrammed number.
2. When the call is connected, the hookswitch indicator will light.
3. The call is terminated by the following: pressing the ON/OFF push button, or the receiving caller hanging up, or the defined timeout of the call duration, or via the SIP Server.

Placing a General Telephone Call

To place a general telephone call:

1. Press the ON/OFF push button.
2. Wait for the dial tone.
3. Use the keypad to dial the desired number.
4. When the call is connected, the "off-hook" indicator will light.
5. The call is terminated by one of the following methods: pressing the ON/OFF push button, the receiving caller hanging up, call duration timeout, or via the SIP Server.

Receiving a Call

When a VoIP Clean Phone® is called, the unit automatically goes off-hook (auto-answer) and a conversation can take place.

Multicast Broadcast

When making a Multicast call, the SIP server will send a paging request to a specific IP address and expect multiple telephones to accept and play the subsequent audio. GAI-Tronics VoIP telephones can be programmed for up to eight Multicast addresses to permit the receipt of Multicast broadcasts from different sources or to enable zoning of broadcasts. Each Multicast address can be assigned a priority (via programming) to define which can override which. A telephone with Multicast enabled can still make and receive normal calls (peer-to-peer or SIP server). Normal calls can be assigned a priority level, defining whether calls can override Multicasts or vice versa.

Monitoring and Reporting

Each telephone can recognize and generate several hardware and configuration fault condition alarms. These alarms can be signaled to a remote site using three methods:

- Syslog output over TCP
- SMTP mail message
- Telephone Management Application (TMA) software (purchased separately)



Available alarms are:

- Handset integrity loop (if applicable)
 - Configuration error
 - Cold reset (power cycle)
 - Warm reset (internal command)
 - Keypad error (if applicable)
 - Key hook (off hook status, if applicable)
 - Register fail
 - Audio Path Test (speaker/microphone test)
-

Installation

General Information

 **WARNING**  **This product can contain hazardous voltages. Always remove power to this station and any associated equipment before beginning any installation.**

 **CAUTION**  **Do not install this equipment in areas other than those indicated on the approval standards listing in the “Specifications” section of this manual. Such installation may cause a safety hazard and consequent injury or property damage.**

Safety Guidelines

When installing any GAI-Tronics equipment, please adhere to the following guidelines to ensure the safety of all personnel:

- Do not install wiring during a lightning storm.
- **Electrostatic Discharge (ESD) Protection:** Your VoIP telephone may have an earth ground terminal provision. If so, ensure that it is connected to ground in accordance with all local safety regulations and the National Electrical Code (NEC). Grounding has to be ensured for safe and stable communications. Do not use long and coiled ground wires. Trim ground wires to the required length. Use a star configuration whenever possible. Please note proper grounding does not eliminate the need for lightning protection for the telephone or the telephone system. A Cat5 data line lightning surge protector is recommended for telephones subject to any electrostatic discharge (e.g. lightning).
- Do not install jacks in wet locations unless the jack is specifically designed for wet locations.

Station Placement

To prevent feedback problems in the system, volume settings and station placement must be taken into consideration. Unpleasant feedback problems can be reduced by:

- Pointing the telephone away from other telephones located nearby
- Reducing volume levels

Feedback problems can be avoided by installing each VoIP Clean Phone® in a separate room and wall.

Model 112-02-0418-00W (Flush mounting)

The mounting and wiring instructions are as follows:

1. Remove the front panel from the back bracket.
2. Refer to Figure 5 on page 10 for cut-out details. Use the cut-out dimensions as a guide to mark the wall, and make the required cuts.

3. If using Power-over-Ethernet, without any optional inputs or outputs, place the bushing around the Ethernet cable so that it is located approximately 120mm from the end of the cable. Snap the bushing closed and insert into the double “D” hole in the bottom of the back bracket. See Figure 3 and Figure 6.

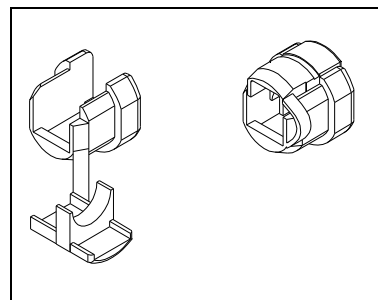

Figure 3. Bushing

4. If using local power or optional inputs or outputs, route the cables through the “D” hole in the bottom of the back bracket. See Figure 6.
5. Place the back bracket in the wall. Locate the mounting holes. Refer to Figure 6.
6. Drill holes in the lower right and upper left corners and secure the bracket with screws. Drill the rest of the holes you intend to use, and secure the bracket with the remaining screws.
7. Plug in the Ethernet cable and connect other optional cables as shown in the “Field Wire Installation” section on page 14.
8. Perform the initial programming of the telephone. Refer to the “Programming” section beginning on page 18.
9. Take the front panel of the VoIP Clean Phone® and align it with four slots in the back bracket.
10. Press the panel in firmly and then push downward to seat the panel in the slots.

NOTE: The Model 112-02-0418-00W is designed for general wipe down cleaning and to prevent collection (internally and externally) of particulate matter. Additional protection against moisture can be attained by sealing between the outer edge of the telephone panel and the mounting surface with silicone or RTV. Any sealing substance used must be verified to be compatible with cleaning solutions used.

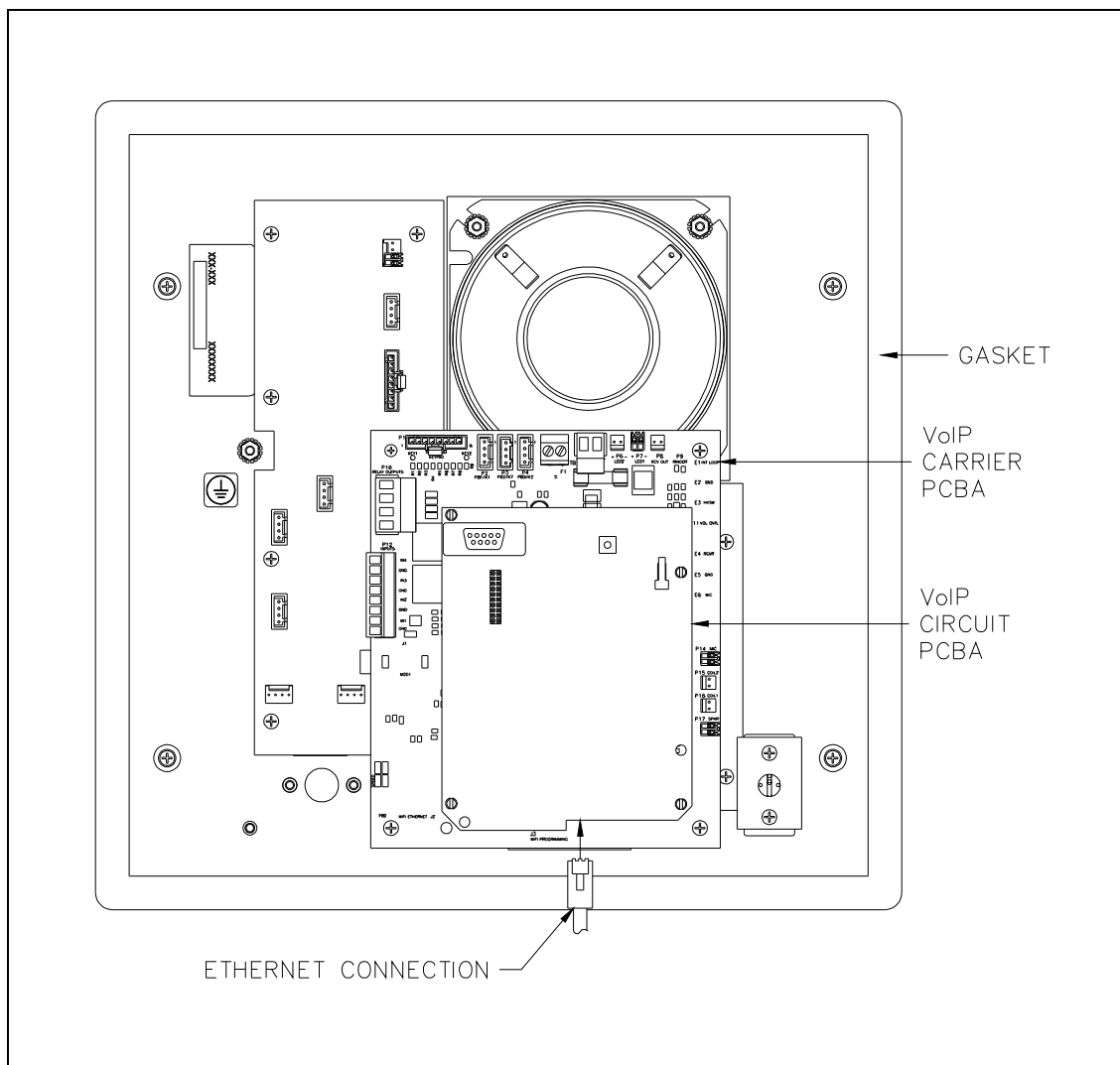

Figure 4. Inside Front Panel

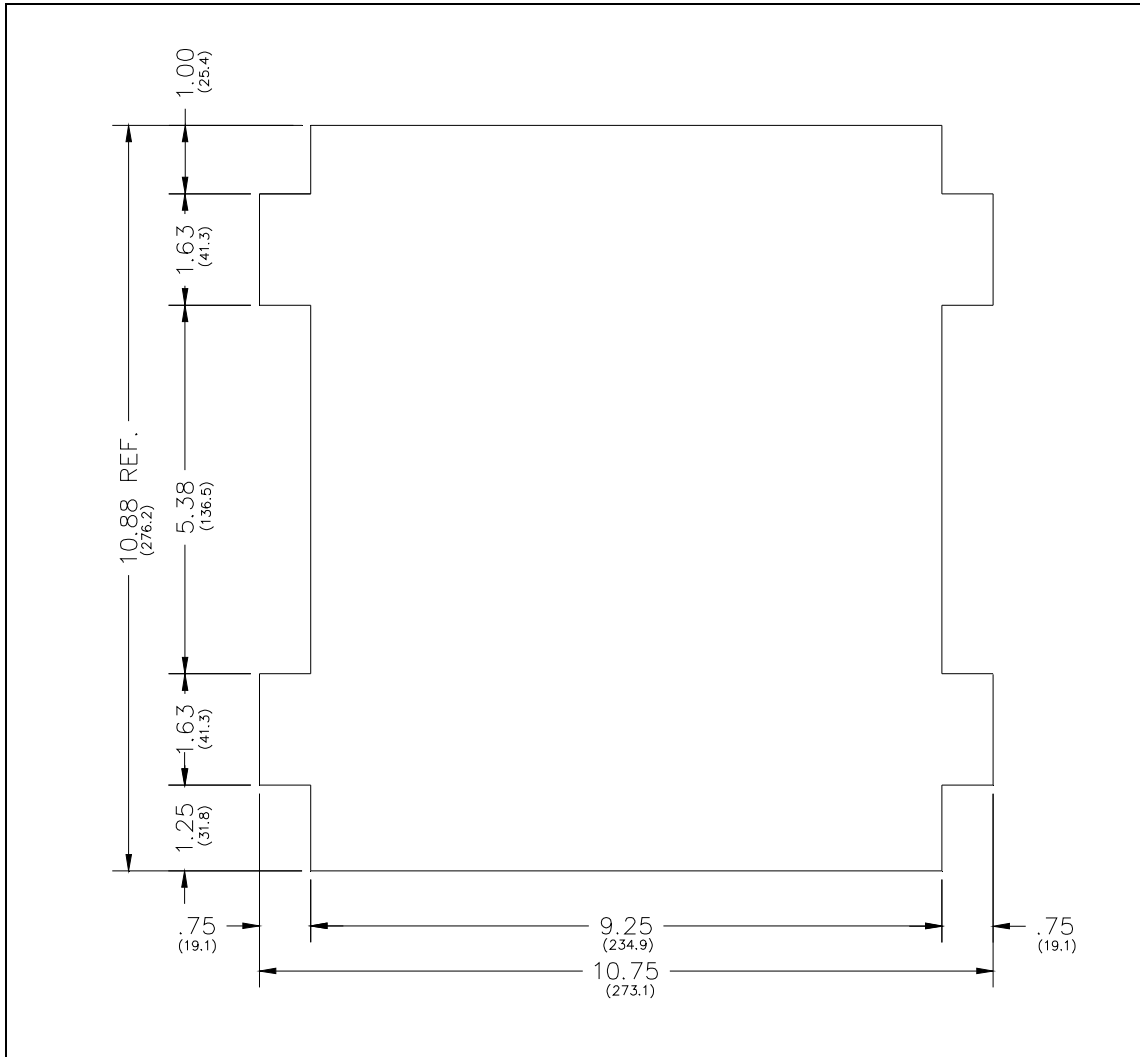

Figure 5. Wall Cut-out Dimensions for Model 112-02-0418-00W

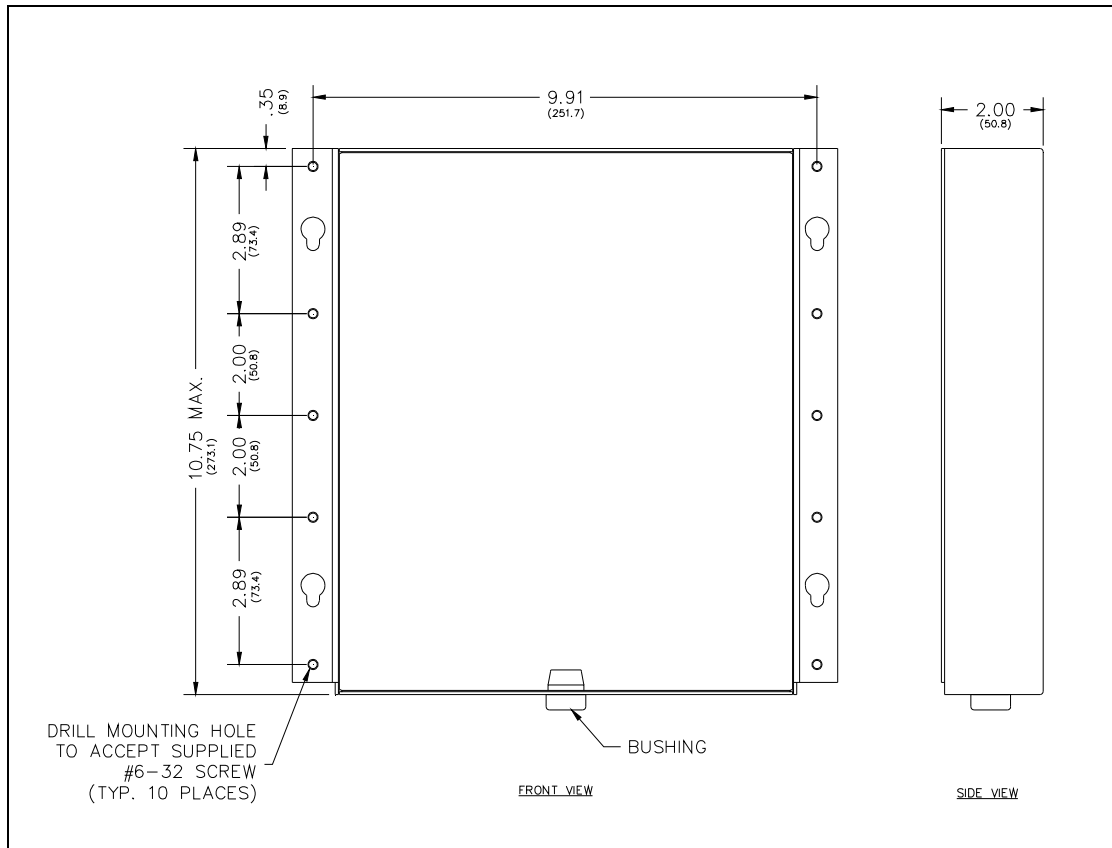

Figure 6. Mounting bracket for Model 112-02-0418-00W

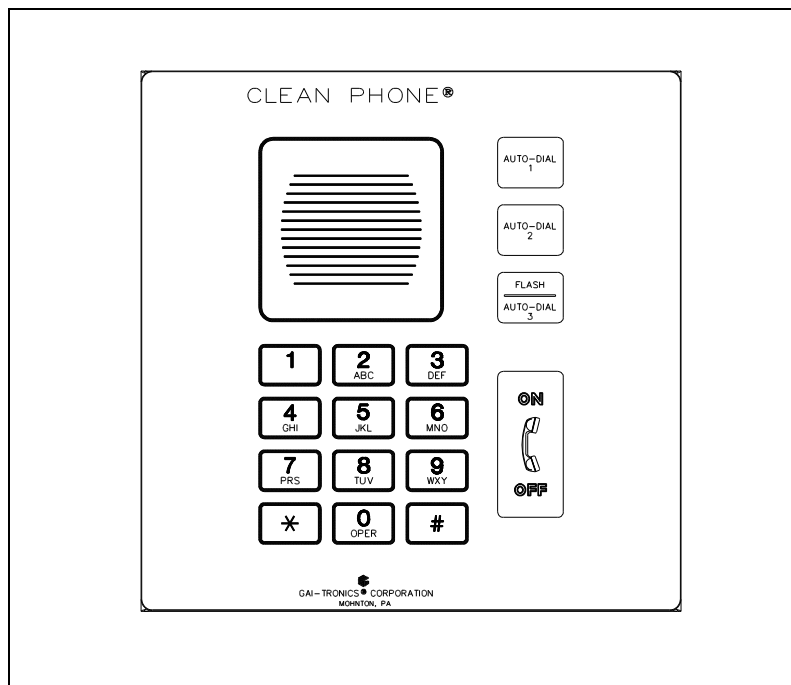

Figure 7. Front Panel

Model 112-02-0418-01W (Surface mounting)

The mounting and wiring instructions are as follows:

1. Remove the front panel from the back box.
2. If using Power-over-Ethernet, without any optional inputs or outputs, place the bushing around the Ethernet cable so that it is located approximately 120mm from the end of the cable. Snap the bushing closed and insert into the double “D” hole in the back box. See Figure 3 and Figure 8.
3. If using local power or optional inputs or outputs, route the cables through the “D” hole in the bottom of the back box. See Figure 3 and Figure 8.
4. Position the back box on the wall, making sure the box is level.
5. Using the back box as a template, drill holes in the lower right and upper left corners, and secure the back box with the screws. Drill the rest of the holes you intend to use, and secure the box with the remaining screws.
6. Plug in the Ethernet cable and connect other optional cables, as shown in the “Field Wire Installation” section on page 14.
7. Perform the initial programming of the telephone. Refer to the “Programming” section beginning on page 18.
8. Take the front panel of the Clean Phone® and align it with the four slots in the back box.
9. Press the panel in firmly, and then push downward to seat the panel in the slots.

NOTE: The Model 112-02-0418-01W is designed for general wipe down cleaning and to prevent collection (internally and externally) of particulate matter.

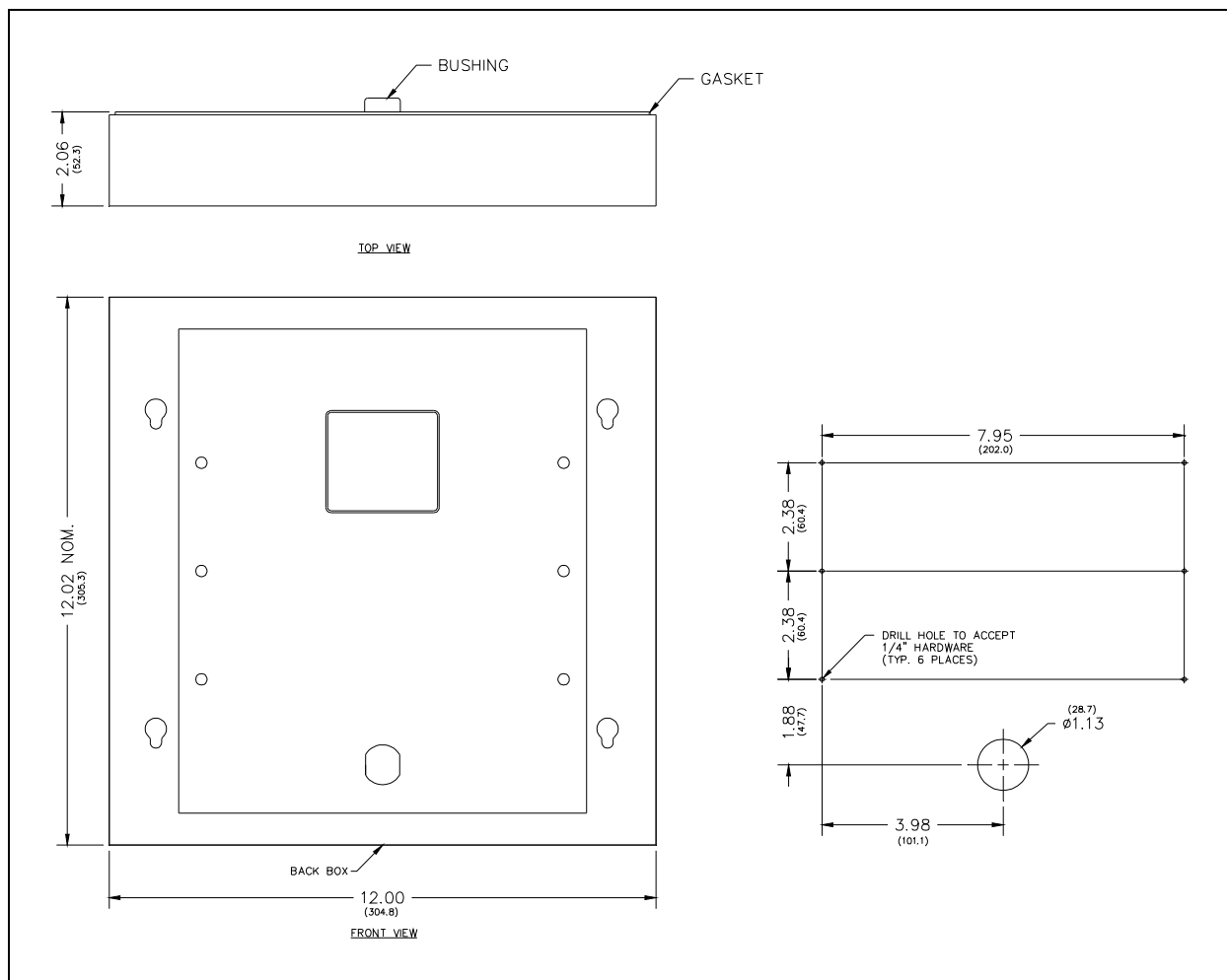

Figure 8. Mounting the Model 112-02-0418-01W

Setup

Field Wire Installation

After all the field wires are pulled through the rear enclosure, install all connections as indicated below. Refer to Figure 9 for wiring details. Refer to Table 5 on page 17 for the recommended conductor sizes.

Power

Power-Over-Ethernet

Connect power to the system as indicated in your PoE equipment manual.

Local Power

When PoE is not available, a separate, isolated 24–48 V dc power supply is required. A removable terminal block P5 has been provided for connection of local power to the telephone. Connect the positive conductor to the (+) terminal and the negative conductor to the (–) terminal of P5. See Figure 9 for wiring and for the location of P5.

Table 2. Power – P5

Pin	Label	Description
1	(+)	Positive
2	(–)	Negative

Ground

The enclosure must be connected to earth ground. Install a #6 ring lug on the ground conductor and secure it with the ground terminal located on the rear of the front panel.

Network

Connect a Cat5 or Cat5e cable with an RJ45 connector between the Local Area Network (LAN) and the VoIP PCBA.

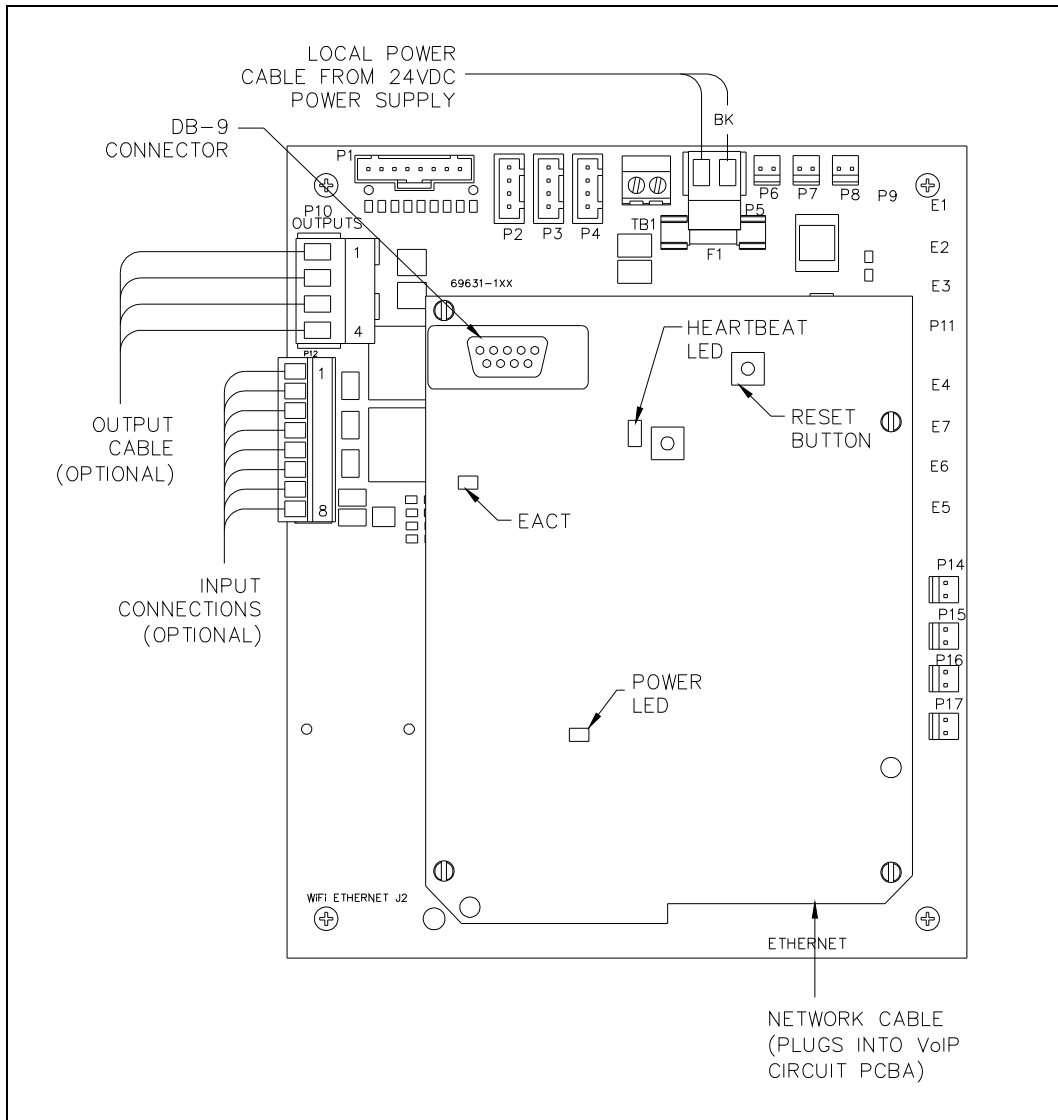

Figure 9. VoIP Telephone PCB Assembly

I/O**Inputs**

Four auxiliary inputs have been provided for customer use. Terminations for these inputs are provided on terminal block P12.

Table 3. Auxiliary Inputs – P12

Pin	Label	Function
1	IN4	Input 4
2	COM	Common
3	IN3	Input 3
4	COM	Common
5	IN2	Input 2
6	COM	Common
7	IN1	Input 1
8	COM	Common

Outputs

Two outputs have been provided for customer use. Terminations for these outputs are provided on connector P10.

Table 4. Output Contacts – P10

Pin	Label	Description
1	C1	Common Output 1
2	NO1	Normally Open Output 1
3	C2	Common Output 2
4	NO2	Normally Open Output 2

Recommended Cabling

Table 5. Recommended Cabling

Cable Use	Size and Type
LAN	Cat5 or Cat5e cable with an RJ45 connector
Power	Two-conductor, No. 22 AWG is typical
Inputs	Two-conductor, No. 22 AWG is typical
Output contacts	Two-conductor, No. 18 AWG is typical

VoIP Telephone Input Contacts

Each VoIP Clean Phone® Telephone accepts four volt-free inputs. Refer to the “Specifications” section of this manual for the input ratings.

The function of each input is configurable. Inputs can be configured for one of the following modes: On, Off, or On/Off. The signals can also be inverted between active high (INVERT) or active low (NORMAL). Activation of these inputs can be configured to update a SYSLOG or generate an email. Please refer to Figure 9 on page 15 of this manual and the “Logic Settings” section of the VoIP Telephone Configuration Guide (available from www.gai-tronics.org/support/voip-support/) for programming instructions for these inputs.

VoIP Telephone Output Contacts

Each VoIP Clean Phone® Telephone contains two voltage-free output contacts. Refer to the “Specifications” section of this manual for the output ratings. Both outputs are single-pole, single-throw contacts.

The function of each output is configurable. Outputs can be configured for one of the following modes: On, Off, Pulse, Mute, Ring, Call, Connect, Hook, In Use, Ring Cadence, Ring Out, Page, Registered, or Emergency. In some modes, the duration of the activation or on/off times can also be set. Please refer to Figure 9 on page 15 of this manual and the “Logic Settings” section of the VoIP Telephone Configuration Guide (available from www.gai-tronics.org/support/voip-support/) for programming instructions for these outputs.

Status Indication

Power

The Power LED located on the VoIP PCBA illuminates when power is applied to the telephone. Please refer to Figure 9 on page 15 for location.

Heartbeat

The Heartbeat LED located on the VoIP PCBA will flash when the telephone is operational over the LAN. Please refer to Figure 9 on page 15 for location.

EACT

The EACT LED located on the VoIP PCBA will turn ON when VoIP PCBA is connected to an Ethernet device and flash when data is being transmitted. Please refer to Figure 9 on page 15 for location.

Programming

The installer should ensure that the network is configured to allow VoIP communications (using the SIP protocol) between the desired locations before attempting to configure the GAI-Tronics VoIP Telephones.

The general sequence for set up of the VoIP Clean Phone® Telephone is as follows:

VoIP PCBA Setup

Verify the PC is connected to the same network as the VoIP telephone.

The easiest way to get started is to make a network connection to the unit and log on via a web browser. The unit is initially set with a static IP address:

IP address 192.168.1.2

A user name and password will be requested. The initial factory settings are:

User Name **user**

Password **password**

Changing the user name and password is recommended. This security measure helps to prevent unauthorized changes to the VoIP Telephone Interface's configuration.

VoIP PCBA Initial Network Configuration

Each VoIP PCBA must be set up for the network prior to installation. Assign a local ID, domain, proxy, and registrar.

Assign a host name The host name provides identification of the different VoIP PCBAs on the network.

Test Verify that calls can be made successfully.

Maintain Monitor alarms. Set up auto-updates.

The phone's home page is as shown below, and allows access to all the other configuration pages. Use the Network IP Settings page to change IP settings appropriate for the intended network.

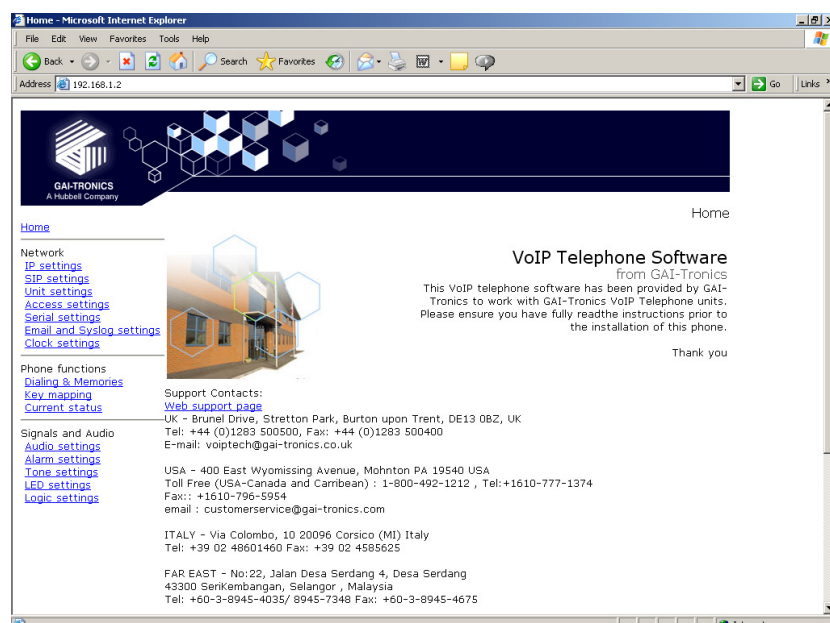

IMPORTANT: After changing the IP address of the telephone you will need to browse to the new IP address to access the configuration, instead of the default 192.168.1.2.

IMPORTANT: If DHCP is enabled, ensure that there is a suitable DHCP server available on the network and that you have a means by which to discover the IP address of the telephone allocated by the DHCP server. There is no other way to access a DHCP enabled VoIP telephone over the network without being able to find the IP address allocated by the DHCP server.

Full help is available from www.gai-tronics.org/support/voip-support/

Maintenance

 **WARNING**  **This product can contain hazardous voltages. Always remove power to this station prior to servicing.**

General Information

1. Inspect and replace frayed or cracked wiring.
2. Secure/replace loose wires and terminal lugs.
3. Remove corrosion from terminals.
4. Inspect fuse F1 on the VoIP Carrier PCBA.

Service

The purchase of your GAI-Tronics product does not end our commitment to you.

In addition to our warranty obligations, GAI-Tronics are able to offer various levels of maintenance packages, installation and commissioning packages and technical support, from ad-hoc repairs to full maintenance contracts.

By choosing GAI-Tronics as your aftercare provider you are ensured of manufacturer expertise and ISO 9001-certified quality control standards throughout the life of the product.

We can also supply a full range of accessories including mounting posts, beacons and high-volume sounders.

Contact GAI-Tronics for details. www.gai-tronics.co.uk

Troubleshooting

Table 6. Troubleshooting Chart

Problem	Possible Solution
Low volume	If the volume is low, increase the volume level in the telephone's programming configuration.
High volume	If the volume is high, decrease the volume level in the telephone's programming configuration.
Front panel push buttons are not operational	Verify the push buttons are properly configured. Verify power is applied to the unit.
Inputs not operational	Check the input connections. Verify the inputs are properly configured.
Outputs not operational	Check the output connections. Verify the outputs are properly configured.
Cannot make or receive calls	Check the connection of the LAN cable. Verify that power is applied to the unit. Verify the LAN parameters have been configured properly. Verify the telephone has been set up on the network.
No power indication	Check the power connections. If using PoE, check the operation of the PoE equipment.

Specifications

Power

Network power..... Power-over-Ethernet, 802.3af compliant (via RJ45)

Local power requirements..... 24–48 V dc, 6 watts

Network..... 10/100 BaseT Ethernet RJ45, Cat5 or Cat5e UTP
Static IP Provisioning or DHCP

Call control signaling..... SIP (RFC3261 compliant) loose routing

Configuration Embedded web server
Configuration file download
Direct serial connection
Password protection

Inputs

Keypad..... 3 × 4 matrix

Push buttons Three autodial and an off-hook indicator/switch

Configurable inputs (quantity = 4)..... Internal pull-up 3.3 V dc tolerant

Outputs

Output 1 2 amps @ 30 V ac/dc (resistive load)

Output 2 2 amps @ 30 V ac/dc (resistive load)

Indicators

External Off-hook indicator light

Internal on VoIP PCBA Power, Heartbeat, & EACT LEDs

Audio output 85 dB SPL or greater @ 1.0 meters (@ 1 kHz)

Mechanical

Temperature range

Operating –4° F to +131° F (–20° C to +55° C)

Storage..... –40° F to 158° F (–40° C to +70° C)

Relative humidity..... Up to 95%, non-condensing

PCBA (printed circuit board assembly) Conformal coated

Chemical Resistance

Clean Phone® graphic overlay is designed to withstand exposure to many chemicals. Please contact the factory for questions pertaining to chemicals not listed below:

Ajax/Vim in solution	Downey/Lenor ¹	Petroleum spirit ¹
Alkal carbonate solution ¹	Ethanol	Phosphoric acid (<30%)
Ammonia (<40%)	Glycerin	Potassium ferricyanide
Acetic Acid (50%)	Glycol	Potassium hydroxide (<30%)
Ariel powder in solution ¹	Gumtion ¹	Pure turpentine
Bleach ¹	Hydrochloric acid (<36.7%)	SBP 60/95 ¹
Castor oil	Hydrogen Peroxide (25% solution)	Sulfuric acid (<10%)
Caustic soda (<40%)	Linseed Oil	Tomato Ketchup
Cutting oil	Methanol	Trichloroacetic acid (<50%)
Cylohexanol	Nitric Acid (<10%)	White spirit
Diacetone alcohol	Paraffin oil	Windex ¹
Diesel	Persil powder in solution ¹	Wisk

¹Extremely faint glossing of the texture was noted.

The Clean Phone® graphic overlay is NOT resistant to the following:

Concentrated mineral acids	High pressure steam at over 100° C	Methylene chloride
Concentrated caustic solution	Benzyl alcohol	UV exposure
Dimethylformamide	Tetrahydrofuran	

Model 112-02-0418-00W Clean Phone®

Construction.....	Front panel: 8 mil polyester over 16-gauge stainless steel Mounting bracket: 16-gauge stainless steel
Dimensions	Front panel: 305 × 305mm Mounting bracket: 273W × 273H × 53D mm

Model 112-02-0418-01W Clean Phone®

Construction.....	Front panel: 8 mil polyester over 16-gauge stainless steel Back enclosure: 16-gauge stainless steel
Dimensions	Front panel: 305 × 305mm Back enclosure: 305W × 305H × 53D mm

Shipping weight & dimensions 5.5kg., 415 × 415 × 100mm

Approval Standards

Safety of Information Technology Equipment	EN 60950-1
EMC.....	EN55022, EN55024



European directives.....	2004/108/EC – EMC Directive
.....	2006/95/EC – Low Voltage Directive (LVD)
.....	2011/65/EC - (RoHS 2) Directive
.....	2002/96/EC - (WEEE) Directive

A copy of the current CE declaration of conformity is available from www.gai-tronics.co.uk

The symbol shown here and on the product means that the product is classed as Electrical or Electronic Equipment and should not be disposed with other household or commercial waste at the end of its working life.



The Waste of Electrical and Electronic Equipment (WEEE) Directive has been put in place to recycle products using best available recovery and recycling techniques to minimise the impact on the environment, treat any hazardous substances and avoid the increasing landfill.

Business users should contact their suppliers and check the terms and conditions of the purchase contract and ensure that this product is not mixed with other commercial waste for disposal.